

NAJAD 355 / 2007

Specifikation 2016

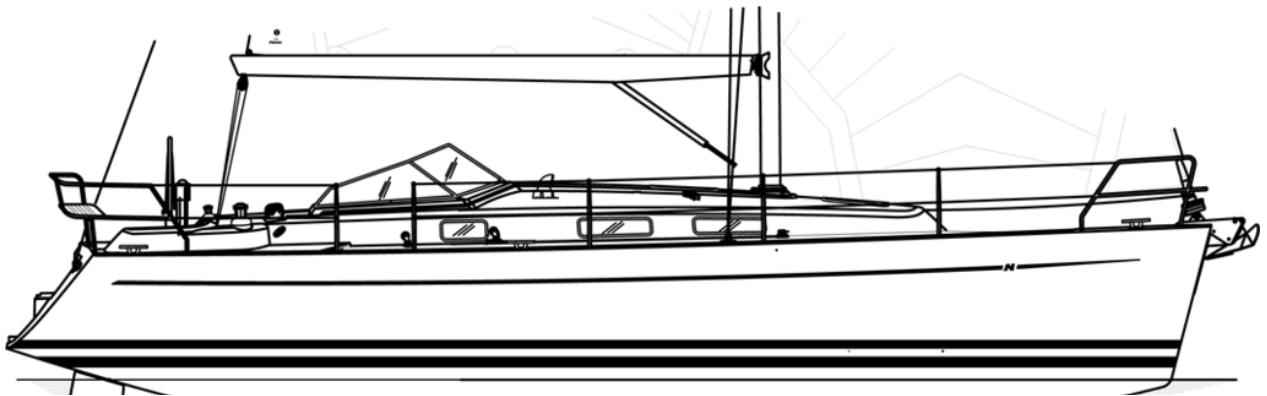



Najad 355 / 2007

A 'world class' yacht

The aim for the successful design of the Najad 355 was to create a luxury, highly exclusive and superb sailing yacht, capable of being handled in safety by a crew of two persons.

Superb sailing characteristics, ergonomic deck layout and a large comfortable cockpit is particularly eye-catching

A truly breath taking interior design from Rhodes Young incorporates a two cabin layout with spacious heads and separate shower compartment and the interior fit and finish is typical Najadvarvet - practicality combined with superb craftsmanship at every level.

Najad 355 is equally suited to the ocean adventurer as to the gentler life of costal cruising and island hopping.

Challenge yourself - built to handle the seven seas and a cockpit dinner for eight...

Key Fact's

In mast furling main sail easy manoeuvred from the cockpit

Electrical furlex

Electrical genua winches

Bow thruster

Info

Model	Najad 355
Yard	Najadvarvet AB
Naval architect's	Judel/Vrolijk
Interior design	Rhodes Young
Delivery year	2007
Location	Sweden, Henån
Price	SEK 1.495.000
VAT	Paid in EU (Sweden)

Data

Length	10,90 m
LVL	9,58 m
Width	3,40 m
Draft	1,90 m
Displacement	6,90 ton
Engine	Volvo D2-40, 40 hp
Fuel	150 L
Water	250 L
Black water	100 + 60 L
Hot water	40 L

NAJAD 355 / 2007

Specification

RIG & SAILS

Rig

In mast furling manoeuvred from cockpit (Seldén)
Electrical Furler for genoa (Seldén)
Back stay adjuster, mechanical (Seldén)
Rodkick with gas damper (Seldén)
Adjustable spi-pole including track on mast and parking position on the deck, 2012
Dynema halyards
Gennaker/Code 0 halyard
Deck light
Steaming light
Tri-color and anchor light
Aluminium rigging screw protection
Windex
2 x Flag halyard

Sails

Mainsail (UK)
Genoa (UK)
Gennaker with squeezer, 2012 (UK)
Code 0 with furler, 2011 (UK)

DECK EQUIPMENT

Winches

2 x Electrical Genoa winch, stainless steel, 2012 (Andersen 40 STE)
2 x Main sheet winch, stainless steel (Andersen 52 ST)
2 x Halyard winch, stainless steel (Andersen 46 ST)

Deck / Sailing equipment

Deck gear (Lewmar/Rutgerson)
Line clutches (Spinlock)
Gennaker/Code 0 equipment, sheets & halyard

Mooring equipment

4 x cleats, stainless steel
2 x spring cleats, stainless steel
2 x Life line gates
6 x Mooring lines
6 x Fenders
Bow ladder "Timo"
Bow platform/Bow sprit
Boat hook

Anchor system

Bow anchor: Electrical windlass, below deck mounted, Delta 15 kg with 40 m x 8 mm galvanized chain
Stern anchor system: Stainless steel 15 kg bruce on folding bracket, 40 m lead line

Skylights, portlights, windows, ventilation

Fixed cockpit windscreen
2 x skylights
8 x portlights (opening type in galley, heads, forward- and aft cabin)
2 x dorade type ventilators

Teak

Solid teak on deck, cockpit, and swim platform

Cockpit

High gloss varnished entrance and chart table with integrated teak grab rails

Foldable, varnished cockpit table

Steering wheel, stainless steel, covered with elk skin

Stainless steel grab rail at the pedestal

Cockpit locker

Sprayhood

Sprayhood extension

Steering pedestal cover

Grab rail behind the sprayhood, elk skin covered

4 x Cockpit cushions

Additional fridge box in cockpit locker, 2013

Misc. deck equipment

Aft deck shower

Safety/Swim ladder

Integrated seats in pushpit

Life sling

INTERIOR

General

Hand made interior of mahogany and Jatoba

Inspection hatches in floorboards

Headlining of cream white covered panels

Layout

2-cabin layout, large heads with separate shower compartment, saloon, galley and navtable

Saloon

Exclusive entrance stair with shaped footsteps and stainless steel handrail covered with black leather. 2 x Sofas and a foldable dinner / coffee table, Navigation area to sb, plenty of cupboards and storage

Galley

The Galley is located to port of the entrance stair. Plenty of storage spaces, cupboards, drawers, dry storage.

Gas stove, 2-burners with oven (Force 10)

Gas valve remote control

Fridge box 92 L

Corian worktop

Single lever fresh water mixer

Aft cabin

Spacious aft cabin with double berth, wardrobe, cupboards and drawers

Forward cabins

Forward cabin with double berth, seat, wardrobe, cupboards and shelves

Heads / Shower

Light and spacious heads with separate shower compartment. Corian bench top and floor board, cupboards for storage, Electrical toilet

Interior details

Alcantara upholstery

Comfortable 8 cm topping mattresses in all berth

Ceiling lights with dimmers

Clock/Barometer in saloon

TECHNICAL SYSTEMS

Engine and Propulsion

Bow thruster (Sleipner SE 80)
Extra insulated engine room
Volvo D1-30S, 28 hp
Fuel pre filter
Sail drive
2-bladed folding propeller

Tanks

Fuel 150 L
Fresh water 250 L
Black water 60 L sea and deck evacuation
Hot water boiler 40 L

Pumps

Manual bilge pump
Electrical bilge pump, high capacity (Rule)

Electrical system

220 V shore power system, 4 x outlets, battery charger 12V/50A (Mastervolt)
12 V service batteries 240 Ah (4 x 120 Ah)
12 V start battery 75 A
12 V bow thruster battery
12 V / 115 A alternator

Navigation system

Compass
Wind, speed, depth instruments (Raymarine ST 60)
Plotter (Raymarine E 80)
Radar 2 kW
Autopilot (Raymarine ST 6002) with gyro module

Communication, Computer and Weather systems

VHF (Ray 54 E)
Antenna for VHF, TV and FM/AM (RR)

Hi-Fi

CD/Radio (Pioneer) 2 x speakers in saloon, 2 x speakers in cockpit
TV/DVD in saloon

Misc. Systems

Eberspracher diesel heater, outlets in cockpit, all cabins and heads

Various on board equipment

2 x Fire extinguisher

Type approval

CE certified category A (unlimited ocean voyages)
Yacht is built in compliance with GL 100 A5

Disclaimer: The Company offers the details of this vessel in good faith but cannot guarantee or warrant the accuracy of this information nor warrant the condition of the vessel. A buyer should instruct his agents, or his surveyors, to investigate such details as the buyer desires validated. This vessel is offered subject to prior sale, price change, or withdrawal without notice.

For further information and booking of viewing please contact:

Magnus Kullberg

+46 701 692 398

magnus.kullberg@xlntyachting.se